

TECHNOLOGY DEVELOPMENT PROJECT FACT SHEET

RT005: SOLAR THERMAL PARABOLIC TROUGH TECHNOLOGY

Trough systems are an alternative to solar photovoltaic systems. This is especially true where there is a need for hot water and electricity. Trough systems absorb the heat from the sun. Because of their parabolic shape, troughs can focus the sun at 30 to 60 times its normal intensity on a receiver pipe located along the focal line of the trough. Synthetic oil captures this heat as the oil circulates through the pipe, reaching temperatures as high as 750°F. The hot oil is pumped through a heat exchanger on the power production side of the plant to produce steam. Electricity is produced in a conventional steam turbine or an organic Rankine cycle machine. The power cycle is completed with the condensing of the steam through a cooling tower and then pumping it back through the heat exchanger connected to the solar energy collection field. The solar trough is more complex than the comparably sized solar PV systems due to the addition of cooling towers, heat exchangers, valves, pumps, turbine, and generator.



Solar Trough
Industrial Solar
Technologies Corporation



Power Block
Ormat Corporation

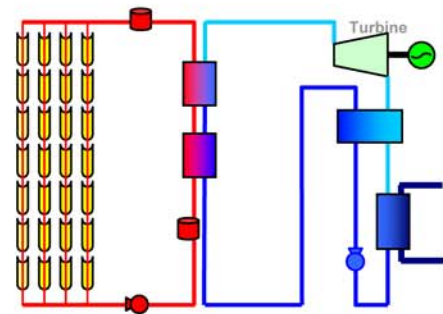

Schematic of a solar thermal parabolic
trough plant Solargenix Energy



Solar Field
Solargenix Energy



Tours are available on the last Wednesday of the month.
For reservations, call Peggy Pearson at (520) 682-2110 x114
Or email at Margaret.Pearson@aps.com

